

Top Access

Powered by
aquabot

Robotic Pool Cleaner
Nettoyeur de Piscine
Automatischer Schwimmbeckenreiniger
Limpiafondos de Piscina
Aspirador Automático de Piscina
Robot di Pulizia per Piscine

Operating Instructions

Mise en marche de votre robot nettoyeur de piscine

Bedienungsanleitung für den automatischen Bodensauger

Funzionamento del nuovo robot di pulizia per piscine

Manejo de Limpiafondos de Piscina

Manual de instruções



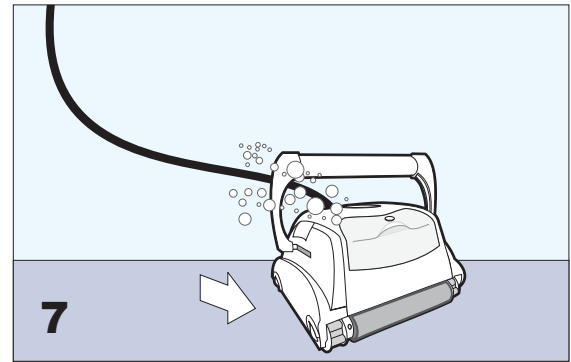
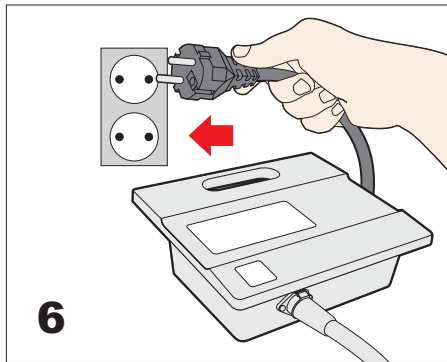
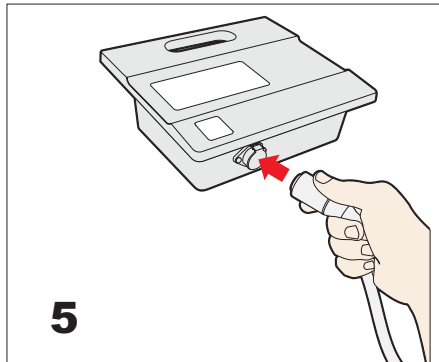
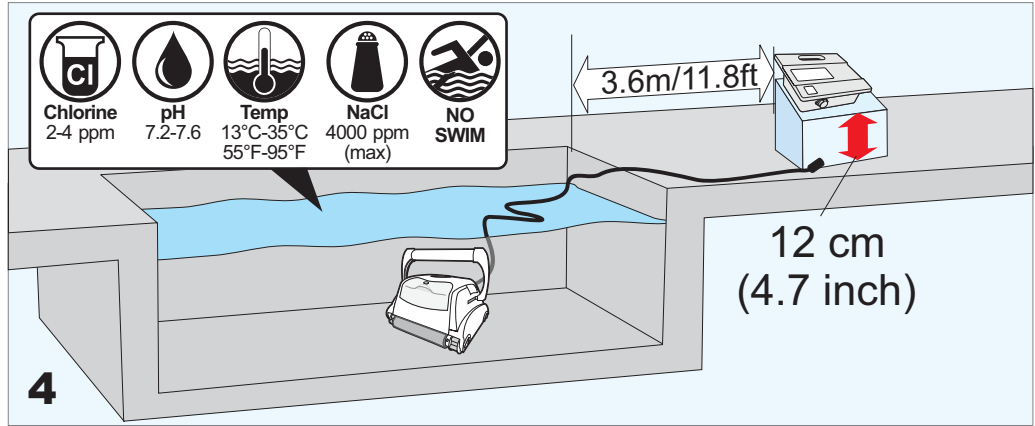
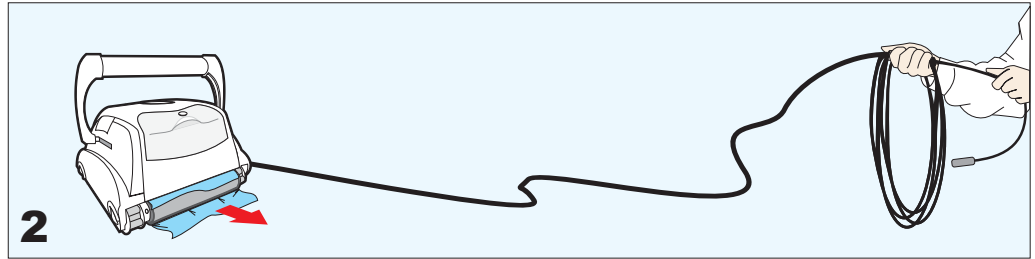
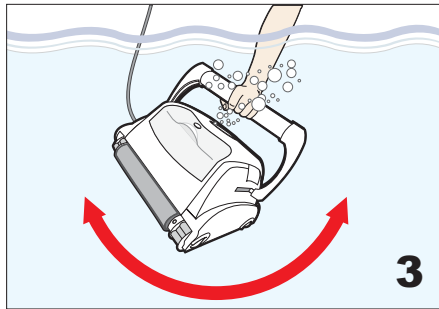
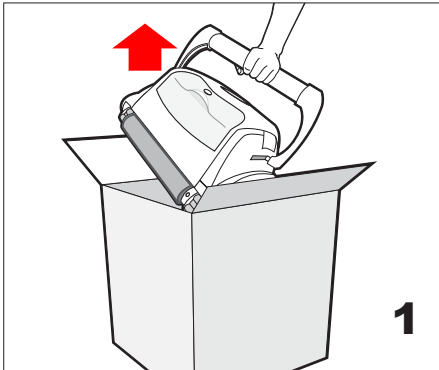

Contents

Safety

Introduction

- System Overview
- How the Robotic Cleaner Cleans Your Pool
- Operating Conditions

Components

- Cleaner And The Main Parts
- Power and Control Unit

Operation

- Before First Use
- Placing Cleaner Unit into the Water
- Starting the Robotic Cleaner
- Cleaning Cycle
- Stopping Robotic Cleaner Operation
- Pulling Cleaner Unit out of the Water

Maintenance

- Cleaning Filters
- Storing the Robotic Cleaner
- Checking Water Outlet Propeller

Robotic Cleaner Programming

- Control Panel - Buttons and Indicators
- Overlay Buttons
- Using an External timer

Troubleshooting

Remote Control

- Remote Control Overview
- Using the Remote Control

Caddy (optional)

- Overview
- Assembling the Caddy
- Loading the Robotic Cleaner on the Caddy

Trolly (optional)

- Overview
- Assembling the Trolly

IMPORTANT SAFETY INSTRUCTIONS READ AND FOLLOW ALL THE INSTRUCTIONS

CAUTION: Do not plug the power supply into a grounded outlet or do not switch the pool cleaner "ON" if it is not fully immersed in water. Operating the cleaner out of water will cause severe damage immediately and will result in loss of warranty.

Allow the cleaner to remain in the pool for 15 to 20 minutes following the end of its cleaning cycle. This will allow the motors to cool adequately. Do not leave the cleaner in the pool all the time. Always remember to turn the power supply "OFF" and unplug it from the power outlet before removing the cleaner from the pool.

WARNING: The cleaner must not be used when people are in the water. For use with swimming pool only

Safety Note

- The unit must be supplied through a residual current device (RCD) having a rated residual operating current not exceeding 30 mA
- The connection to the branch circuit should be consistent with the local and national wiring rules (electrical code).
- Mishandling of the unit can result in leakage of lubricants.
- If the supply cord is damaged, it must be replaced by the manufacturer's service agent or a qualified and trained person in order to avoid hazards.



This appliance is not intended for use by persons (including children) with reduced physical, sensory or mental capabilities, or lack of experience and knowledge, unless they have been given supervision or instruction concerning use of the appliance by a person responsible for their safety. Children should be supervised to ensure that they do not play with the appliance.



WARNING: A Ground Fault Current Interrupter (GFCI-USA) or a Residual Current Device (RCD-EUROPE) must be installed to protect your electric outlet and prevent any possible electric shock.

SAVE THESE INSTRUCTIONS

Introduction

System Overview

The robotic cleaner sweeps the pool floor and walls to collect dirt and debris into its internal filters. This user manual explains how to operate the robotic cleaner, including cleaning, maintenance and storage procedures.

Note:

This manual reviews several robotic cleaner models. There are some variations in components according to specific model.

How the Robotic Cleaner Cleans Your Pool

After the robotic cleaner is placed in the pool and activated, it operates according to the program set via the power and control unit. The robotic cleaner moves along the floor and walls of the pool, covering the entire area of the pool floor and walls. When the robotic cleaner has finished its program, it remains inactive on the pool floor.

Note:

Wall climbing is an optional feature. When the wall climbing feature is enabled, the robotic cleaner climbs the wall at intervals according to its internal program. The robotic cleaner ability to climb over stairs in swimming pool is subject to stair geometry and material.

Operating Conditions

The robotic cleaner is intended for use in swimming pools in the following conditions:

- Temperatures ranging from 13°C-35°C (55°F-95°F), recommended temperature is between 22°C-32°C (72°F-90°F).
- Water pH: 7.2 - 7.6
- Chlorine level: pool is maintained according to the pool manufacturer's instructions. (recommended 2-4 ppm)

Note:

Failure to maintain the pool according to the recommended operating conditions could prevent the robotic cleaner from functioning properly. Remove the cleaner out of water when performing "Chemical Shock Treatment" to the pool water.

Components

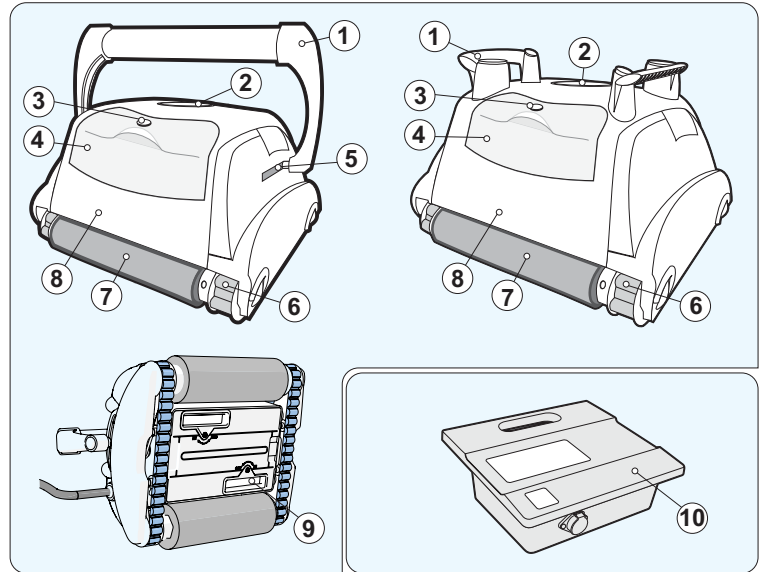

- 1) Handle
- 2) Outlet Top
- 3) Filter Lock Release
- 4) Filter Top Access
- 5) Handle Lock Mechanism
- 6) Drive Track
- 7) Scrubbing Brush
- 8) Unit Body
- 9) Water Inlet
- 10) Power Supply

OPTIONAL

- 11) Remote Control
- 12) "Trolley" Cart
- 13) "Caddy" Cart
- 14) Timer (purchased separately)

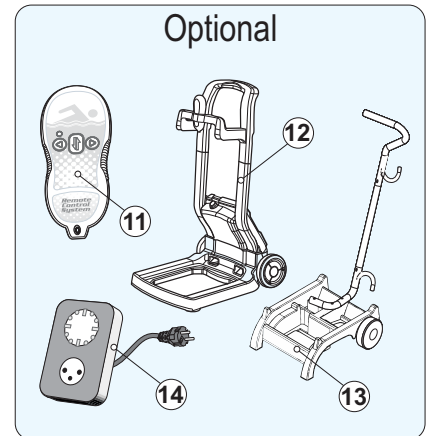

Components

Power and Control Unit

The power and control unit is connected to the robotic cleaner via the floating cable. The unit is powered by AC power (1) and supplies low voltage and commands to the cleaner unit through the outlet socket (2).

The unit features a control panel (3) with various controls to operate the robotic cleaner.

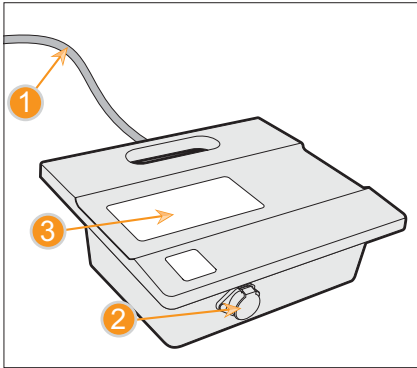

Contents of Packing Box

The robotic cleaner is packed in a box containing:

- Robotic cleaner and floating cable
- Power and control unit
- User manual

According to the model purchased, the following accessories may be included in the package:

- Remote Control
- Caddy
- Trolley
- Additional Accessories

Operation

Before First Use

Adjusting Suction Height: Positioning the suction inlet (2) close to the pool surface increases the suction power and the cleaning quality. Lowering the suction inlet could result in interference with obstacles on the swimming pool floor or walls.

Use a screw driver to adjust the suction inlet position knob (1).

- IN – pulls the suction inlet away from the pool surface and reduces the suction power.
- OUT – brings the suction inlet closer to the pool surface and increases the suction power.

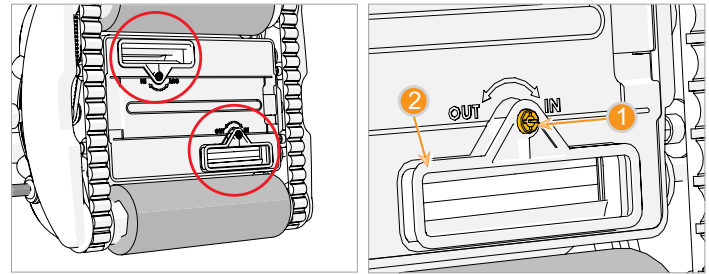

Adjusting Floating Handle

On wall climbing models, set the floating handle:

1. Press the lock button (1 or 2 according to the model) to release the handle lock.
2. Place the handle (3) diagonally at maximum position.
3. Repeat steps 1 and 2 on the other side of the cleaner unit.

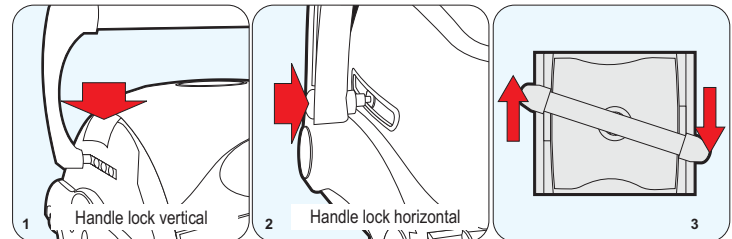

Operation

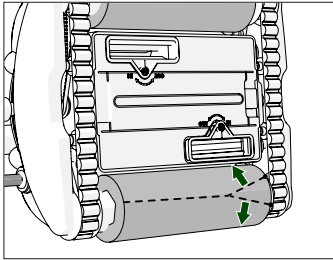

Removing Brush Covers

The robotic cleaner is shipped with a protective cover over the scrubbing brushes. Carefully remove the nylon covers from the scrubbing brushes.

CAUTION: Do not use a sharp tool to remove the cover as it could harm the brushes.

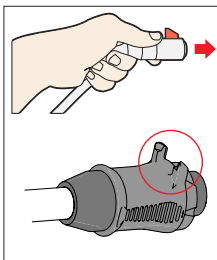
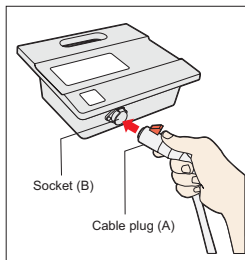
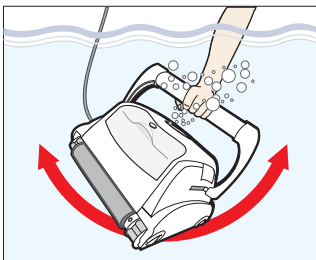
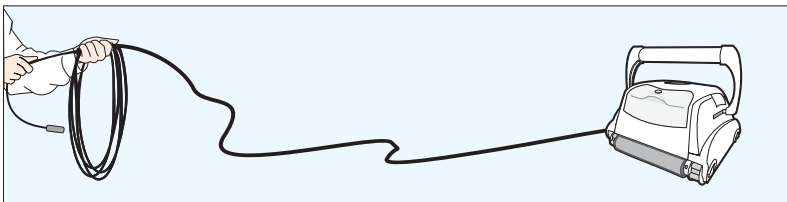
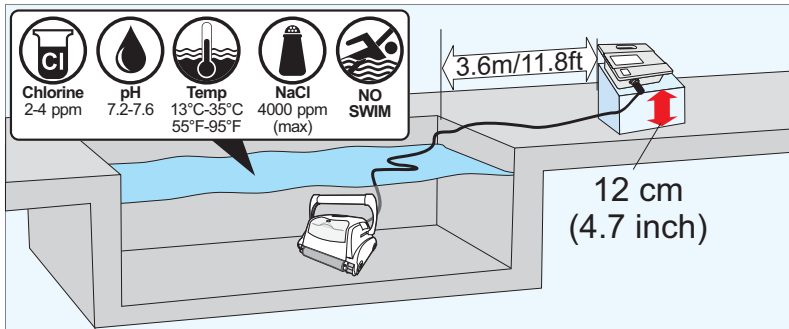

Placing the Power and Control Unit

4. Place the power and control unit at least 3.6 meters/11.8 feet from the pool and at least 12 cm/4 inches above the surface.

CAUTION: The power and control unit must not be exposed to water or to direct sunlight.

5. Release floating cable plastic ties, which are used to secure the cables during shipping, by pressing plastic snap on the tie.

Before placing the cleaner unit in the water

1. Make sure there are no people in the pool.
2. Make sure that the filters are clean.
3. Make sure the pool conditions are met; (see "Operating Conditions").

Placing Cleaner Unit into the Water

1. Unroll the floating cable. It is recommended to extend a length of cable that is equal to the pool diagonal size plus an additional two meters.
2. Place the cleaner unit in the pool.
3. Let the robotic cleaner sink to the bottom of the pool.
Do not start operation before the robotic cleaner is settled on the pool floor.
4. Spread the floating cable across the pool. Make sure that only the required length of cable is spread across the pool. Smooth out coils or twists in the cable. Roll extra cable outside the pool near the power and control unit.
5. Connect the floating cable (A) to the socket (B) located on the power and control unit.

CAUTION: Operating the cleaner out of water causes immediate severe damage and results in loss of warranty.

Operation

Starting the Robotic Cleaner

Connect the power and control unit to the wall socket (1). The Operation LED is lit (4) and the robotic cleaner starts its cleaning program.

If the power and control unit is already connected to the AC socket, the Operation LED flashes (5) to indicate that the robotic cleaner is in standby mode.

Press the Operation button (6). The Operation LED turns on (6) and the robotic cleaner starts the cleaning program.

Note: *When the Check Filter LED (3) (optional in some models.) is lit, the robotic cleaner filters must be cleaned before placing the cleaner unit in the pool.*

Cleaning Cycle

During the cleaning cycle, the robotic cleaner:

- Moves across the pool floor picking up dirt and debris.
- Changes direction and rotates automatically according to the selected program
- Climbs the pool walls every few minutes, as set in its internal program.

Note: *The robotic cleaner might occasionally stop moving for a few seconds. This is part of normal operation, not a malfunction.*

Stopping Robotic Cleaner Operation

The robotic cleaner moves automatically to STANDBY after every cleaning cycle and the operation LED starts flashing (5).

To stop the cleaner operation during a cleaning cycle, press the operation button (7) once. The operation LED starts flashing (7) and the cleaner is in standby mode.

Pulling Cleaner Unit out of the Water

1. Unplug the floating cable from the power and control unit.
2. Pull up on the floating cable to pull the cleaner unit closer until it is possible to take hold of the handle.
3. Using the handle, lift the cleaner unit out of the pool.

CAUTION: *Do not use the floating cable to lift the cleaner unit out of the water.*

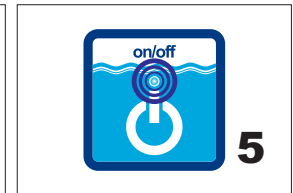
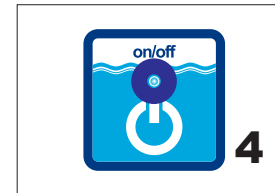
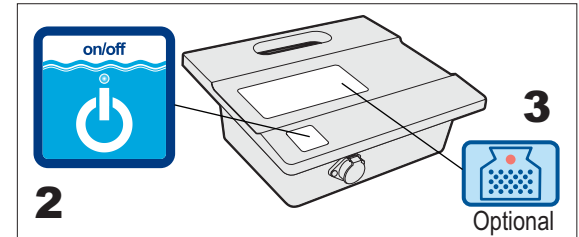
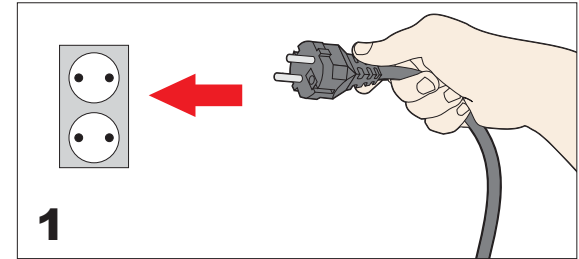

Maintenance

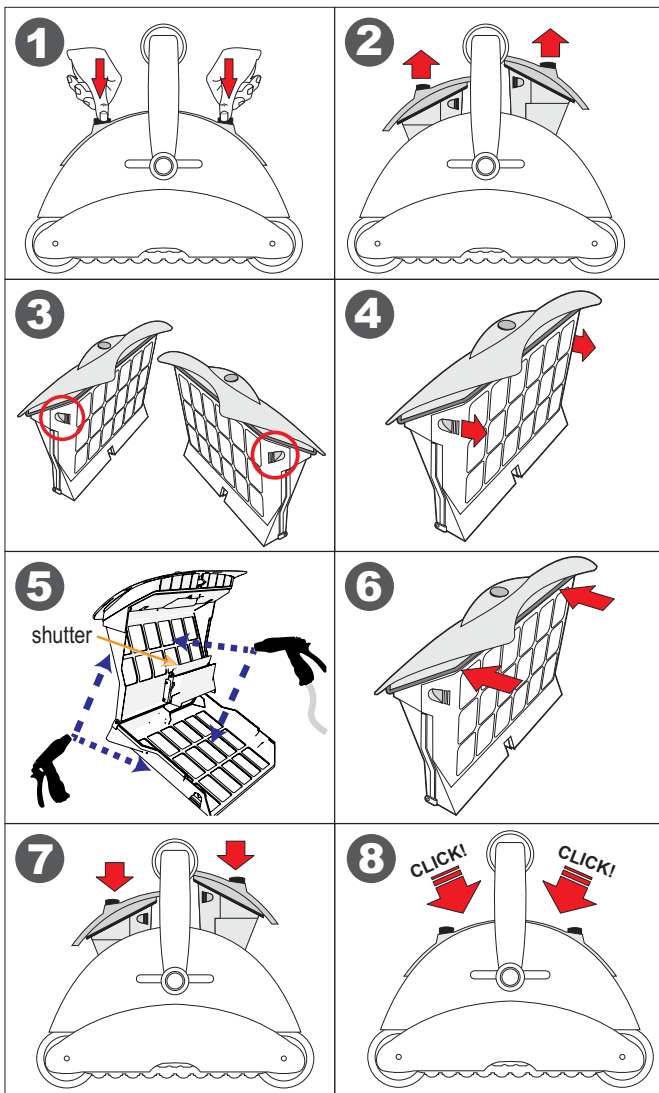

Cleaning the Filters

The two filters must be cleaned after each cleaning cycle.

1. Release the filter and pull it out of the cleaner unit. (1), (2)
2. Pull the filter door against the filter housing to open the filter case. (3), (4)
3. Spray water on the outer sides of the filter and then spray water towards the inner side of the filter to clean all the dirt and debris. (5)
4. Verify that the small plastic shutter (2) is in place and not broken, then close the filter. (6)
5. Insert the filter back into its location until a click is heard to secure the filter in place. (7), (8)

Storing the Robotic Cleaner

Follow these instructions to store the robotic cleaner when not in use:

1. Disconnect the power cord from the wall outlet.
 2. Disconnect the floating cable from the power and control unit.
 3. Spread out the floating cable and release any twists in the cable.
 4. Wash the cleaner unit interior space with fresh water and let it dry.
 5. Roll the floating cable and place it ON THE CLEANER unit.
- Caution: DO NOT ROLL the floating cable ON THE HANDLE of the cleaner unit.**
6. Store the robotic cleaner components in a dry, closed location.
 7. Verify that the power and control unit is not exposed to water.



Checking Water Outlet Propeller

It is recommended to periodically clean debris and hair from the propeller of the water outlet:

1. Remove the screws (3) that holds water outlet cover (2).
2. Remove the water outlet cover (2).
3. Clean any hairs, dirt, or debris.
4. Verify that the propeller (1) is not broken.
5. Return the cover (2) and fasten it with the screws (3).

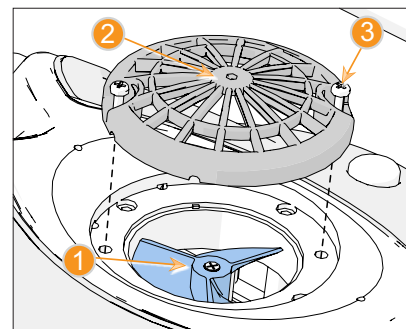

This chapter reviews the programming options. Skip this chapter if your model is not programmable or if the robotic cleaner is already programmed.

Aquacontrol



check filter
chèque filtre
filter überprüfen
controllare il sacchetto filtrante
revise el filtro



cleaning time
temps de nettoyage
reinigungszeit
tempo di pulizia
tiempo de limpieza

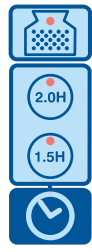

SPS 100

Aquacontrol



Cleaning program
Mode nettoyage
Programa de limpieza
Reinigungsprogramm
Programma di pulizia
Programa de limpeza

Internal timer
Minuterie interne
Temporizador interno
Interne Zeitschaltuhr
Timer interno
Temporizador interno

Check filter
Vérifiez le filtre
Revise el filtro
Filter überprüfen
Controllare il sacchetto filtrante
Verifique o Filtro

External timer
Minuterie externe
Temporizador externo
Externe Zeitschaltuhr
Timer externo
Temporizador externo

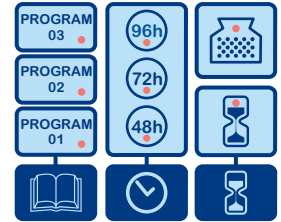

SPS 200

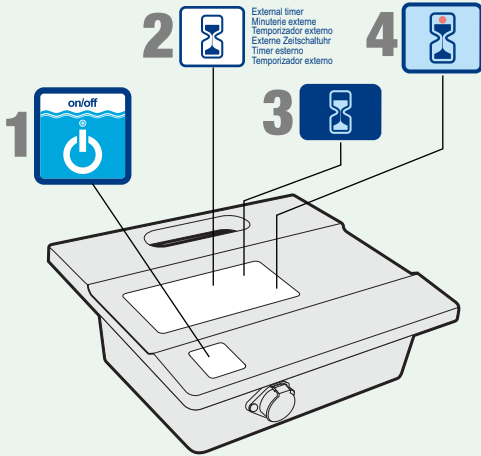

Control Panel

The control panel consists of:

- On/Off power (1) – starts and stops the robotic cleaner operation.
- Function description (2) – describes the function
- Control buttons (3) – dark blue, enables selecting relevant function.
- Status display (4) – indication LED lit to display the selected option or the cleaner state.

Aquacontrol



Swivel
Pivot
Swivel
Drehflügel
Manopla di disattorcigliamento
Swivel

Cleaning program
Mode nettoyage
Programa de limpieza
Reinigungsprogramm
Programma di pulizia
Programa de limpeza

Internal timer
Minuterie interne
Temporizador interno
Interne Zeitschaltuhr
Timer interno



Check filter
Vérifiez le filtre
Revise el filtro
Filter überprüfen
Controllare il sacchetto filtrante
Verifique o Filtro

External timer
Minuterie externe
Temporizador externo
Externe Zeitschaltuhr
Timer externo
Temporizador externo



SPS 300

Aquacontrol

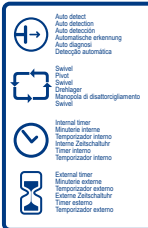

Auto detect
Auto detection
Auto detección
Automatische Erkennung
Auto diagnosi
Detección automática

Swivel
Pivot
Swivel
Drehflügel
Manopla di disattorcigliamento
Swivel

Cleaning program
Mode nettoyage
Programa de limpieza
Reinigungsprogramm
Programma di pulizia
Programa de limpeza

Internal timer
Minuterie interne
Temporizador interno
Interne Zeitschaltuhr
Timer interno

External timer
Minuterie externe
Temporizador externo
Externe Zeitschaltuhr
Timer externo
Temporizador externo

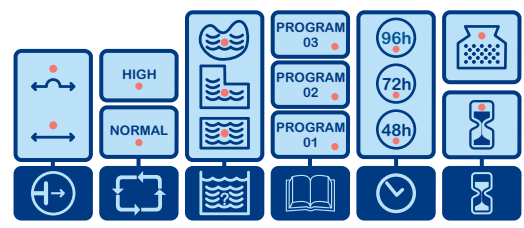

SPS 400

Aquacontrol



Auto detect
Auto detection
Auto detección
Automatische Erkennung
Auto diagnosi
Detección automática

Swivel
Pivot
Swivel
Drehflügel
Manopla di disattorcigliamento
Swivel

Cleaning level
Niveau de Nettoyage
Nível de Limpeza
Reinigungsstufe
Livello di Pulizia
Nível de Limpieza

Delay
Retard
Retraso
Verzögerung
Ritardo

External timer
Minuterie externe
Temporizador externo
Externe Zeitschaltuhr
Timer externo
Temporizador externo

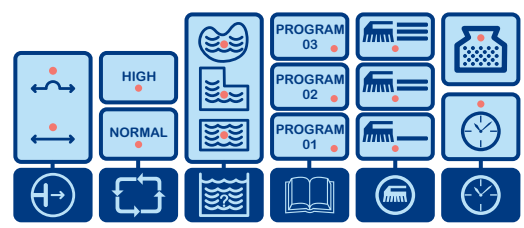

SPS 500

100/200
300/400
500



Check filter

- Illuminated light means the filter bag must be removed, cleaned and properly installed back into the robot to work efficiently.

100



Cleaning time

- time duration spent cleaning the pool.

Press the button to select the desired time. A red light will indicate your selection.

This feature can only be selected when the Power supply is in standby mode

200
300/400



Internal timer - Automatic operation option:

Every 48 hours

Every 72 hours

Every 96 hours

200/300



Cleaning program selection:

Program 01 – 1 hour floor and wall cleaning

Program 02 – 1.5 hour floor and wall cleaning.

Program 03 – 2 hour floor and wall cleaning.

400



Cleaning program selection:

Program 01 – 1.5 hour floor only cleaning program

Program 02 – 2 hour floor and wall cleaning.

Program 03 – 2.5 hour floor and wall cleaning.

500



Cleaning program selection.

Program 01 – 2 hour floor only cleaning program

Program 02 – 4 hour floor and wall cleaning. (on certain models wall cleaning feature is not available)

Program 03 – 5 hour floor and wall cleaning. (on certain models wall cleaning feature is not available)

200
300/400



External timer

This feature gives the option to the end user to program the cleaning schedule through an external timer (sold separately). Pressing this button enables and disables this feature.

300/400
500



Swivel – adjust the robots rate of turns in the pool.

Normal – Standard operation

High – Different rate of turns

400/500



Auto detect: this feature prevents the robot from getting stuck on obstacles in the pool such as main drains, steps, ladders etc. Press this button to choose one of the following options:



Auto-Detect - OFF. Choose this option if your pool has obstacles on the floor such as high drain. This will prevent the unit from changing direction upon hitting the obstacle.



Auto-Detect - ON. Choose this option if the pool floor is free of obstacles.

400/500



Pool shape:

Allows the robot to calculate the most efficient cleaning pattern for the pool shape chosen. Press the button to select the drawing most suitable to the shape of the pool. A red light will indicate your selection.

500



Cleaning level – Change the cleaning performance



Quick: Choose if your pool has small amount of dirt

Regular: Choose for daily maintenance

Thorough: Choose if your pool has large amount of dirt

500



Delay

When this option is On, the robot will start to work after 2 hours of delay.

This feature is used to let debris and dust sink on the floor before starting the robot's cleaning.

External Timer

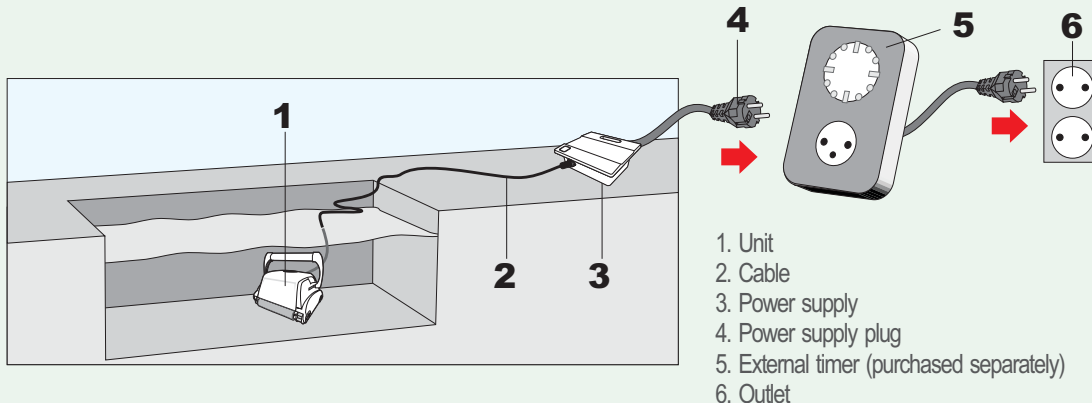

1. Unit
2. Cable
3. Power supply
4. Power supply plug
5. External timer (purchased separately)
6. Outlet

Using External Timer

(Optional, should be purchased separately)

An external timer can be used to automatically activate the Cleaner on pre-set time.

The external timer should be connected between the wall socket and the Power and Control unit

Troubleshooting

CLEANER DOES NOT TURN ON.

There is no electricity in the wall socket.

1. Disconnect cleaner from the power and control unit.
2. Disconnect power supply from the wall socket, wait 30 seconds and reconnect.
3. Turn power ON. If not activated, connect the unit to a different wall socket.

Floating cable not connected properly to the power and control unit.

Reconnect the floating cable to the power and control unit.

Obstacle in the drive system of the cleaner unit.

1. Turn the cleaner unit carefully to view the underside.
2. Rotate the tracks and scrubbing brushes by hand. It should rotate but it should not rotate freely.
3. Clean and remove obstacles and debris if necessary.

Propeller is seized due to accumulation of hair.

Check if the propeller is broken or needs to be cleaned (see “Checking Water Outlet Propeller”).

CLEANER MOVES BUT DOES NOT PUMP WATER.

Filters are dirty.

1. Remove the filters
2. Run the robotic cleaner in the pool without the filters. If working properly, clean the filters well or replace the filters.

Propeller is broken or seized due to accumulation of hair.

Check if the propeller is broken or needs cleaning (see “Checking Water Outlet Propeller”).

CLEANER PUMPS WATER BUT DOES NOT MOVE.

Obstacle in the drive system of the cleaner unit.

1. Turn the cleaner unit carefully to view the underside.
2. Rotate the tracks and scrubbing brushes by hand. It should rotate but it should not rotate freely.
3. Clean and remove obstacles and debris if necessary.

CLEANER STARTS AND SHUTS OFF AFTER A SHORT TIME.

Filters are dirty.

1. Remove the filters.
2. Run the robotic cleaner without the filters. If working properly, clean the filters well or replace the filters..

Propeller is broken or seized due to accumulation of hair.

1. Remove the top screws on the top outlet.
2. Check if the propeller is broken or needs to be cleaned.

Obstacle in the drive system of the cleaner unit.

1. Turn the cleaner unit carefully to view the underside.
2. Rotate the tracks and scrubbing brushes by hand. It should rotate but it should not rotate freely.
3. Clean and remove obstacles and debris if necessary.

CLEANER DOES NOT PICK UP DIRT.

Filters are dirty or have holes.

Clean as needed and verify that there no holes in the filters.

Propeller is broken or seized due to accumulation of hair.

Check if the propeller is broken or needs cleaning (see “Checking Water Outlet Propeller”).

The suction inlet is not close enough to the pool floor.

Move the suction inlet OUT (see “Adjusting Suction Height”).

DIRT COMES OUT OF THE CLEANER WHEN REMOVING IT FROM POOL.

Filter shutter is broken or missing.

Open the filters and verify that the filter shutter is not broken and functions properly (see “Cleaning Filters”)

Holes in the filters.

Open the filters and verify that there are no holes in the filter screens (see “Cleaning Filters”)

Bottom lid is not properly closed.

Make sure that the bottom lid is properly closed.

Troubleshooting

CLEANER UNIT DOES NOT COVER THE ENTIRE POOL.

Filters are dirty.

Clean the filters.

There is not enough length of the floating cable in the water to reach the far end of the pool, or the cable is tangled.

1. Verify that there is enough length of the floating cable in the water to reach the far end of the pool.
2. Make sure that the floating cable is properly spread out and is not tangled.

The angle of the floating handle affects the cleaner movement.

Increase diagonal angle of the floating handle (see “Adjusting Floating Handle”).

Pool pH level is incorrect.

Make sure that the pH level is between 7.2 and 7.6.

Chlorine level is incorrect.

Check water chlorine treatment and correct if required (Remove the cleaner from the pool during the treatment.)

Propeller is broken or seized due to accumulation of hair.

1. Remove the top screws on the top outlet.
2. Check if the propeller is broken or needs cleaning.

Obstacle in the drive system of the cleaner unit.

1. Turn the cleaner unit carefully to view the underside.
2. Rotate the tracks and scrubbing brushes by hand. It should rotate but it should not rotate freely.
3. Clean and remove obstacles and debris if necessary.

THE CLEANER DOES NOT CLIMB WALLS.

The cleaner is not climbing the pool walls.

1. Verify that your robotic cleaner is not a floor-only model.
2. Verify that P1, floor cleaning only, is not selected on the power and control unit (see “Robotic Cleaner Programming”).

Filters are dirty.

Clean the filters.

Propeller is broken or seized due to accumulation of hair.

Check if the propeller is broken or needs cleaning (see “Checking Water Outlet Propeller”).

pH level is incorrect.

Make sure that pH is between 7.2 and 7.6.

Chlorine level is incorrect.

Check water chlorine treatment (remove the cleaner from the pool during treatment).

Water temperature is not optimal.

Recommended temperature is between 22°C–32°C (72°F–90°F).

THE CABLE IS TANGLED.

Filters are dirty.

Clean the filters.

Bottom lid is not properly closed.

Make sure that the bottom lid is properly closed.

Cable is not spread out before putting the cleaner unit into the pool.

Make sure that the floating cable is properly spread out and not tangled before operating the robotic cleaner.

The length of the cable in the water is too long.

Verify that the length of cable in the water equal to the pool diagonal length plus two meters.

Propeller is broken or seized due to accumulation of hair.

Check if the propeller is broken or needs cleaning (see “Checking Water Outlet Propeller”).

REMOTE CONTROL DOES NOT WORK.

The battery is empty. The LED is blinking or OFF.

Check the battery by pressing one of the buttons. The red light on the remote control unit does not blink or stay lit continuously if the battery is empty. Contact your dealer or service center.

Remote Control (optional)

This chapter reviews the operation of the optional remote control unit. The remote control is included in some models.

Remote Control Overview

The remote control is an optional feature that enables controlling the robotic cleaner via remote command buttons. When pressing the remote control buttons, radio signal is transmitted to the power and control unit. This signal is transferred into a command sent to the robotic cleaner via the floating cable.

Using the Remote Control

1. Press the right button (3) to turn the robotic cleaner right. The robotic cleaner continues turning to the right until the button is released.
2. Press the left button (1) to turn the robotic cleaner left. The robotic cleaner continues turning to the left until the button is released.
3. Press the Forward/Reverse button (2) to stop the robotic cleaner and change its direction of movement.

The remote control LED is lit after each command. If the LED does not respond or flashing, replace the battery.

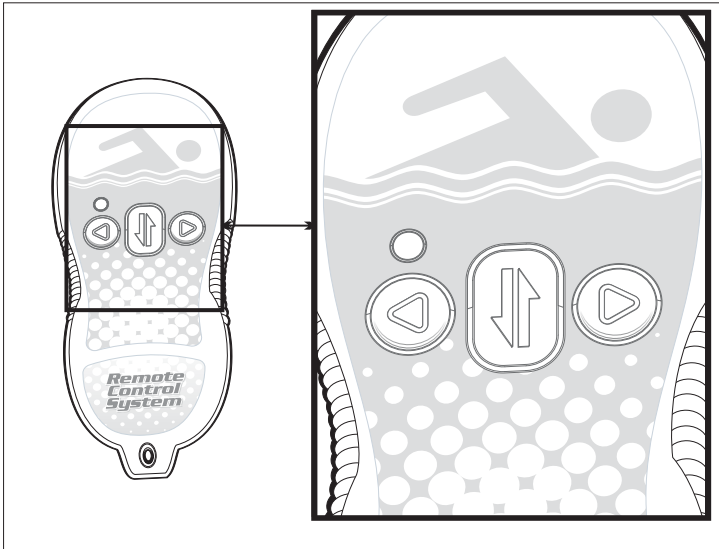

Caddy (optional)

The caddy is an optional accessory that makes it easy to move the robotic cleaner, floating cable and the power and control unit from place to place.

Assembling the Caddy

To assemble the caddy, you need a standard screwdriver and a 8 mm wrench.

Connecting the Caddy Handle

1. Fasten the handle bottom part (3) to the caddy frame (5) with the three screws (4) and nuts.
2. Connect the handle top part (1) to the handle bottom part (3) using screw (2) and nut.

Loading the Robotic Cleaner on the Caddy

1. Place the cleaner unit on the caddy base.
2. Coil the floating cable and place it on the cleaner unit.
3. Place the power and control unit on top of the floating cable coil.

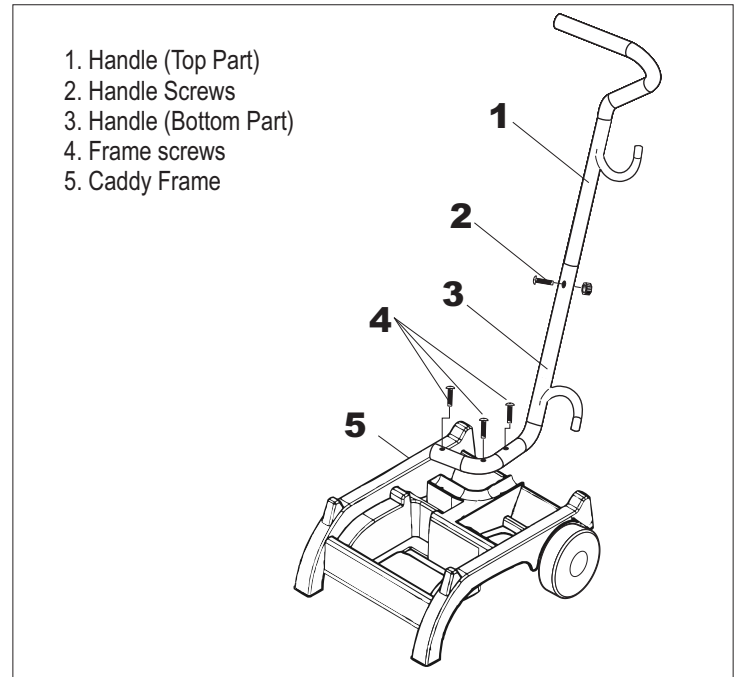

Trolley (optional)

Assembly Diagram

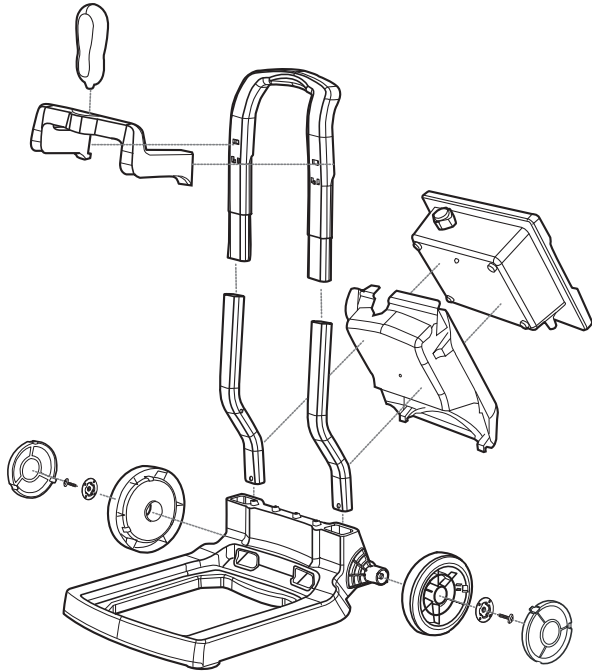

The trolley is an optional accessory that makes it easy to move the robotic cleaner and provides a mounting site for the power and control unit.

To assemble the trolley:

1. Attach the wheels to both sides of the trolley base and fasten each wheel with the screw and install the cover.
2. Assemble the two sections of the handle.
3. Attach the power and control unit housing by clicking the upper tabs into the holes in the handle.

Parts

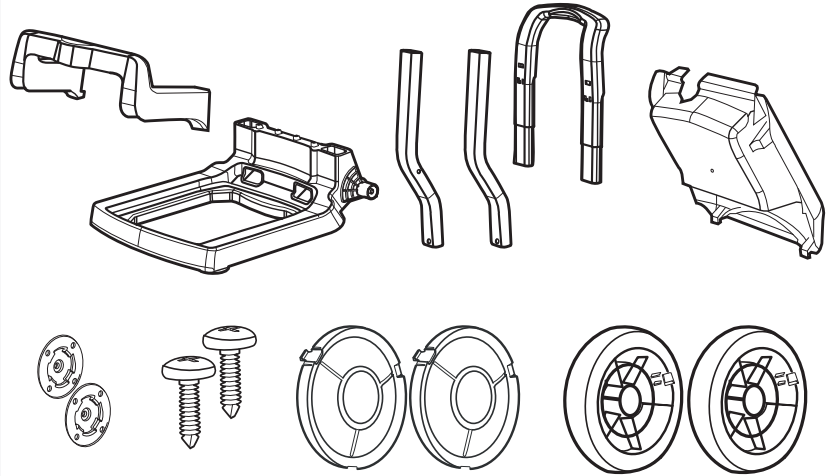

1

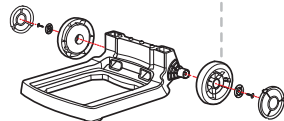
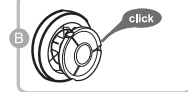
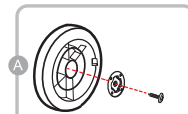

2

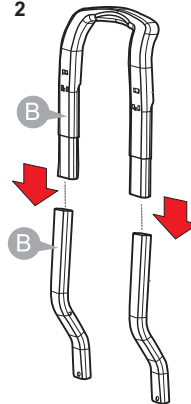

3

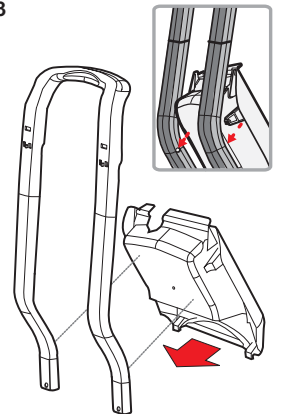

Trolley (optional)

4. Insert the handle into the trolley base. Click the lower tabs of the power and control unit housing into the trolley base.
5. Attach the remote control holder by inserting the upper part into the trolley handle and turning the holder downward until the lower part clicks.
6. Attach the cable of the power supply
7. Place the power and control unit in the housing and push the lower part downward until it clicks into the trolley base.
8. Place the upper part of the power and control unit in the housing and push the lower part downward until it clicks into the trolley base.

